

## 1 Fixation de la base au sol Fix the mast base to the ground

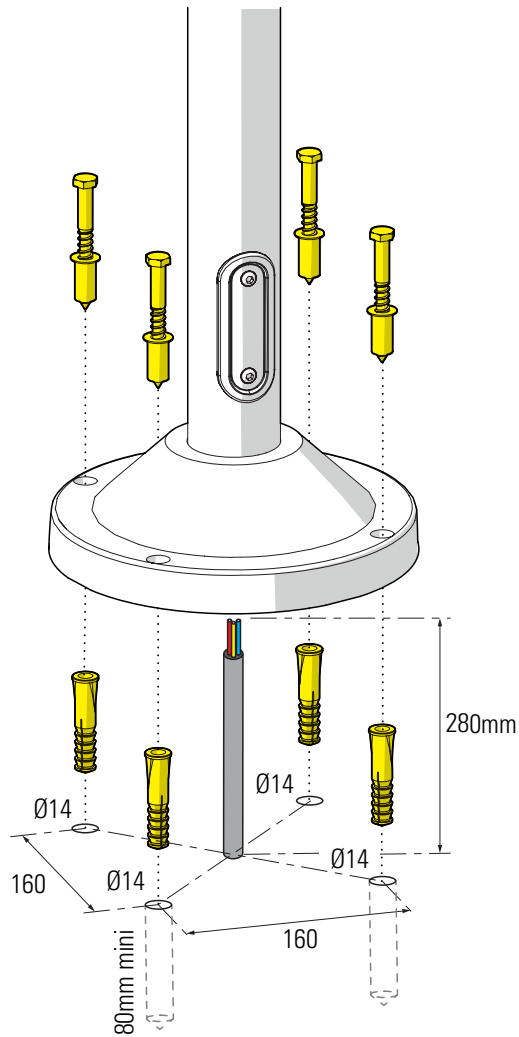

## 2 Montage de la lampe & du globe Install the light-bulb & globe

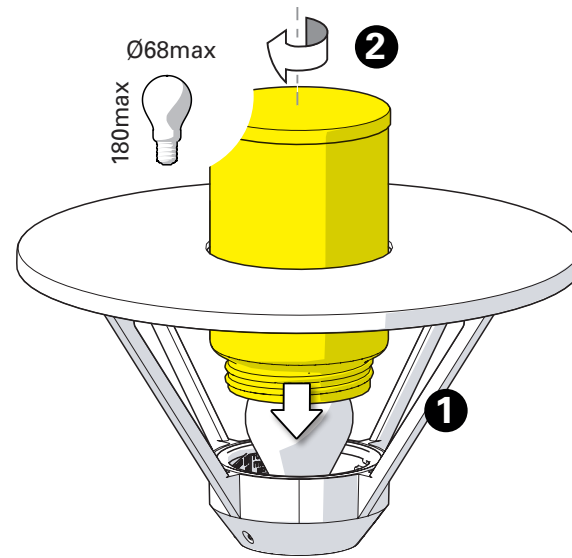

## 3 Raccordement électrique Connect electrical wires

